





**Team NLM—
Groundbreaking Innovator
of Aluminum and Beyond**

Mission of the NLM Group (Corporate Philosophy)

Be forever committed to the development of new applications for aluminum and aluminum-related materials and thereby contribute to the improvement of people's quality of life and environmental protection.

Message from the President & CEO

Since its establishment, the NLM Group has been a comprehensive manufacturer of aluminum products with diverse offerings ranging from aluminum raw materials to fabricated products.

Aluminum is lightweight, strong and possesses many other superb properties such as workability, corrosion resistance, thermal conductivity, electrical conductivity, and recyclability. These characteristics have made it the metal of choice for many applications that greatly benefit society.

The NLM Group develops aluminum and aluminum-related materials to supply highly diversified products for a wide range of industries. Our products all leverage the NLM Group's core strengths: highly original technologies for making the most of aluminum's properties, and a wealth of knowledge and expertise amassed over the years.

Team NLM—Groundbreaking Innovator of Aluminum and Beyond

Everyone at the NLM Group is working together as a single, united team to ensure that customers can rely on us and will continue to choose the NLM Group as a partner. We are deploying the Group's comprehensive capacities to completely satisfy the heartfelt aspirations of every customer and create value that our customers appreciate. We are leveraging the Group's wealth of knowledge and technology to go beyond being a mere materials manufacturer and take our business as a group to an entirely new level.



We always deeply ponder the question, "What will bring joy to our customers?" In that spirit, we are pursuing sustainable growth by vigorously pursuing the limitless and new possibilities arising with the changing times.

As we strive to improve the Group's overall corporate value by doing business in this manner, we remain committed to supporting customers in a wide variety of industries, thereby contributing to the improvement of people's quality of life and environmental protection.

I. Okamoto

Ichiro Okamoto
President and Chief Executive Officer

Contents

<p>The Basis of the NLM Group's Total Solutions</p> <p>1 NLM Group Business Sectors P.3</p> <p>2 Market Presence and Corporate Social Responsibility..... P.5</p> <p>3 Superior Innovation P.7</p>	<p>Business Fields</p> <p>1 Automobiles P.9</p> <p>2 Machinery, Electronics, and Communications P.11</p> <p>3 Environment, Safety, and Energy P.13</p> <p>4 Public Works, Landscape, Construction P.15</p> <p>5 Transportation P.17</p> <p>6 Food, Health & Industrial Products P.19</p>	<p>Global ReachP.21</p> <p>Corporate Profile / Corporate History.....P.23</p> <p>List of Major Group Companies.....P.25</p>
---	--	--

As a comprehensive manufacturer, the NLM Group provides total solutions, from aluminum materials to semi-manufactured and fully fabricated products.

As a comprehensive manufacturer, the NLM Group has established an aluminum production organization focused on its four main businesses. We produce high quality, high value added products.

Aluminum Ingot and Chemicals

The NLM Group manufactures a wide variety of chemicals such as alumina and aluminum hydroxide used in aluminum raw materials such as flame retardants, ceramics, and grinding materials. In addition, we manufacture high purity aluminum and aluminum alloys at the highest levels of industrial production in the world.

Aluminum Ingot and Chemicals

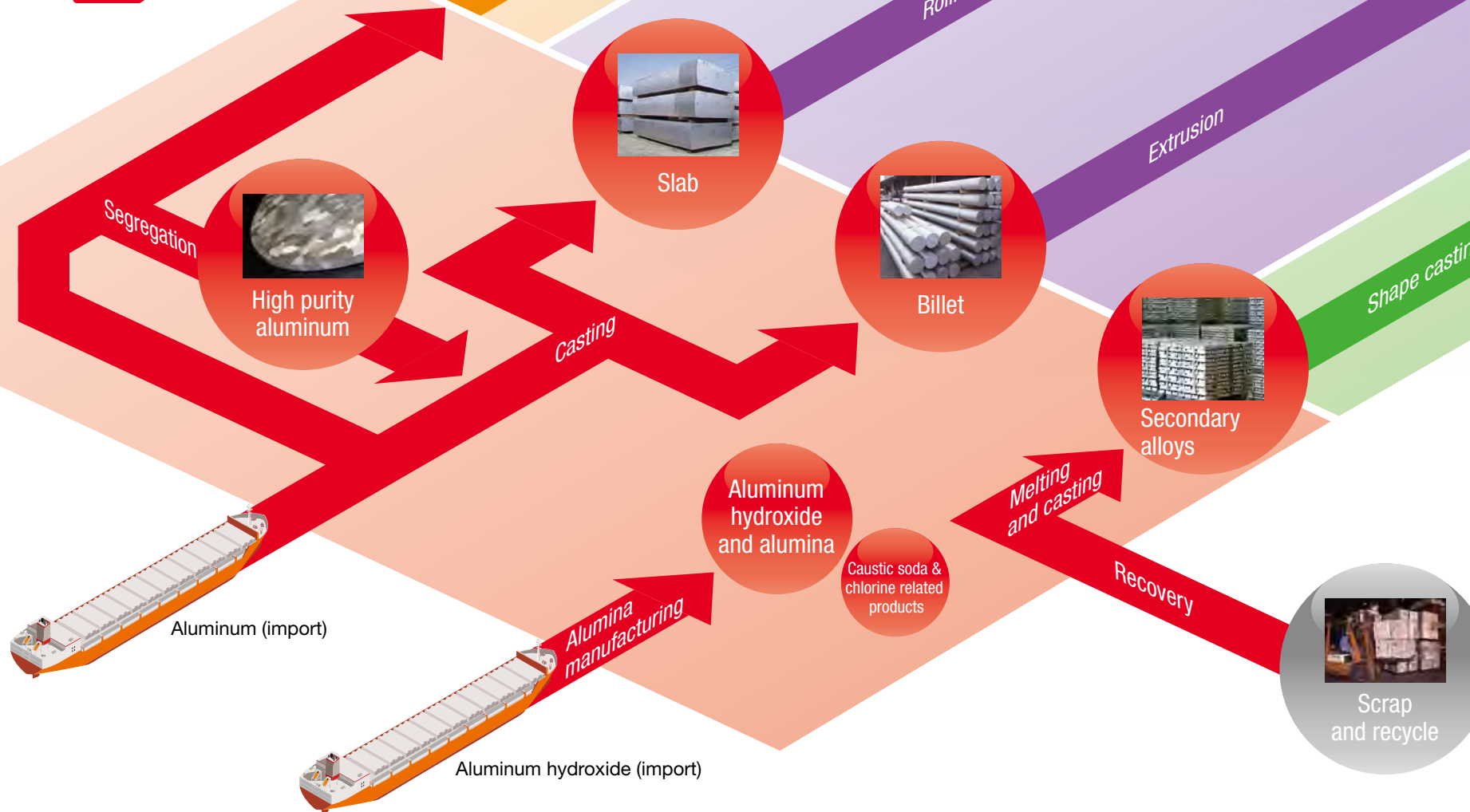

A wide range of products for society

- Automobiles..... P.9
- Machinery, Electronics, and Communications..... P.11
- Environment, Safety, and Energy..... P.13
- Public Works, Landscape, Construction..... P.15
- Transportation..... P.17
- Food, Health & Industrial Products..... P.19

Aluminum Foil, Powder and Paste

Foil products
Powder products
Paste products
Solar cell related products

Variety of fabricated products

Automotive parts, transportation related products, electronic materials, panel products, heat exchanging products, food containers, landscaping products, building products, carbon products, etc.

Fabricated Products and Others

Aluminum Foil, Powder and Paste

The NLM Group constantly pursues the full possibilities of aluminum through innovative research and high precision material fabrication technology. We also create multi-material products with resins, films, and other materials to offer a wide variety of high quality, high performance aluminum foils, powders, and pastes.

Fabricated Products and Others

The NLM Group offers a wide variety of extremely reputable, fabricated aluminum products such as aluminum foil for electrolytic capacitors, automotive parts, landscaping products, and building materials, such as those used in van and truck bodies, commercial refrigerator and freezer panels, and clean room panels.

Aluminum Sheet and Extrusions

The NLM Group offers aluminum sheets and extrusions for a diverse range of fields, including transportation, machinery, and electronics. We are applying our advanced designs and structural analysis technology to create many high precision, high quality sheets, as well as highly complex-shaped, difficult-to-manufacture extrusions.

Spotlight

Hydroelectric Power to Support Business Activities

The Nippon Light Metal Company utilizes the strong current of the Fuji River with two dams and six power plants to provide stable power to its Kambara Complex. The total amount of power generated is 142,500 kW, making it possible to supply most of the power needs of the complex.

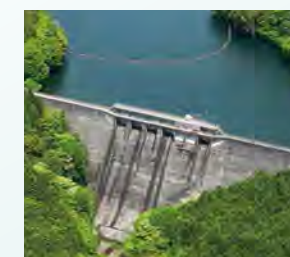

Kakimoto Dam



Amahata Dam

The NLM Group's Yokogushi Development Platform*1 leverages the Group's comprehensive capacities to meet diverse customer needs.

Spotlight

Yokogushi Development Platform facilitates a single team driving business development

All the Group's employees share a single mindset: "explore customer needs and then find the right solution." Based on that spirit, the NLM Group uses a workflow of "explore, create, make, and sell" to produce high value added products and services that are competitive in the marketplace.

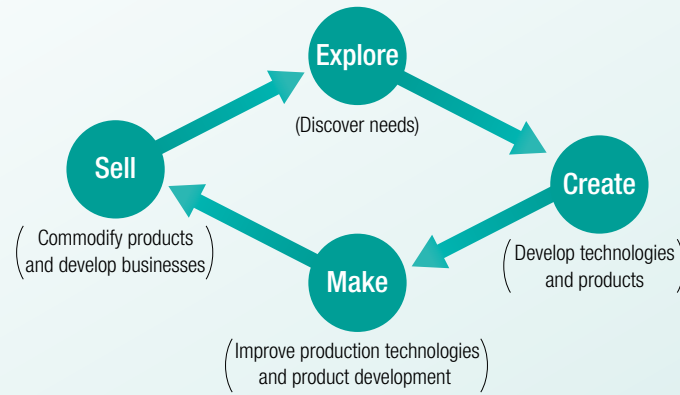

*1 Yokogushi Development Platform: A cross-functional platform for developing multifunctional products

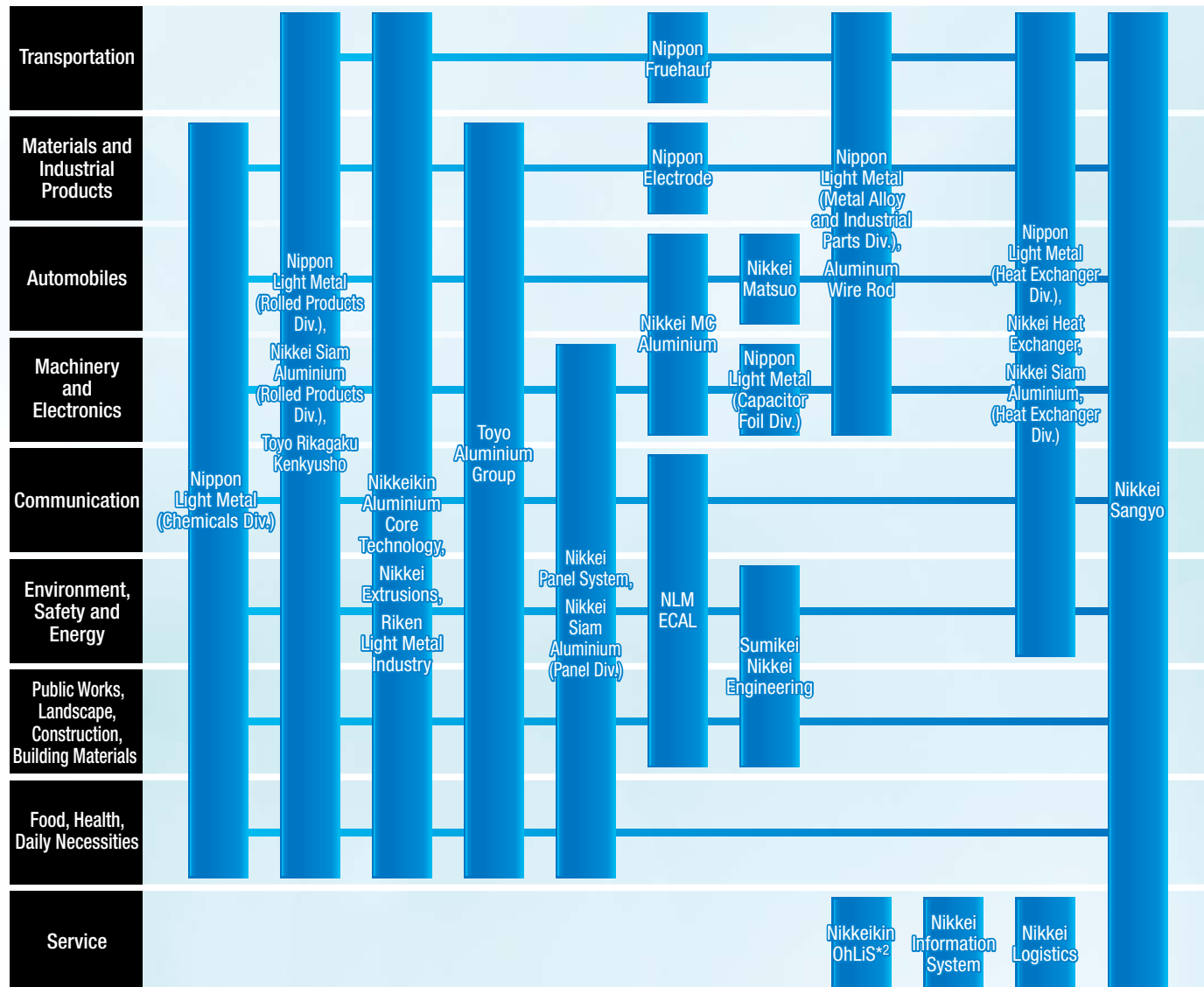

*2 Special Subsidiary Company

Spotlight

Corporate Governance

The NLM Group uses a holding company system. Under the umbrella of Nippon Light Metal Holdings, the two core operating companies are Nippon Light Metal and Toyo Aluminium.

The NLM Group forms and decides on overall group strategies, distributes business resources strategically, and manages its respective companies to achieve sustained growth while strengthening its competitiveness with the goal of increasing its corporate value. (See page 23 for more about management organization.) In addition, as part of our effort to strengthen corporate governance, we are organizing and improving internal control systems, strengthening compliance positioning, and actively implementing risk management.

The NLM Group is also striving to build an organization that always lives up to our corporate governance code. We are taking steady steps to address each principle of the code in order to realize effective corporate governance.



The NLM Group distributes its management policy and compliance handbook to all employees to ensure that the content takes root group-wide. (Back [left to right]: Thai, Chinese, English; Front: Japanese)

Spotlight

Improving Product Safety and Quality

The NLM Group has obtained ISO 9001 international quality assurance certification (covering 55 sites as of September 2017) to ensure the quality and safety of the services and products provided by all of its companies.

The NLM Group conducts group training to develop internal auditors. Further strengthening quality assurance activities, the Central Product Safety & Quality Assurance Division, which reports directly to the president of NLM Holdings, performs these roles: (1) quality diagnosis, namely periodic quality audits to confirm that the quality assurance organization within the Group is effective; (2) quality *jishuken*, namely self-directed *kaizen* continuous improvement activities; and (3) other quality training activities (why-why analysis, process FMEA, etc.).

In this way, the NLM Group is working hard to raise the bar on its quality assurance and to foster the next generation of quality assurance staff.

Examination meetings are held prior to the start of production to allow the top executives of each company to issue final approval of product and new business development and to ensure that there are no problems with safety, quality, and cost.



Quality education activities (basic education for quality management)



Quality diagnosis in action (China)

Spotlight

Environmental Preservation and Health & Safety

The NLM Group Environmental Committee deliberates and decides upon basic measures such as action plans related to the Group's environment management. The committee is composed of directors of NLM Holdings and presidents of each group company. The NLM Group collaborates with each of its factories and offices to ensure operations are in accordance with the ISO 14001 international environment management system (31 sites in Japan and 11 outside Japan certified as of March 2018). In doing so, the Group pursues group-wide eco-friendly initiatives such as pollution prevention, compliance with environmental laws, reduction of greenhouse gas emissions, energy conservation, and biodiversity conservation.

In addition, we prioritize elimination of industrial accidents over all other activities, including Group-led measures to comply with health and safety laws, ensure safety in all operations, improve conditions to ensure proper workplace hygiene, and implement mental health measures.

The NLM Group establishes midterm action guidelines at its Group Safety and Health Committee, comprising group company presidents, safety chiefs, and representatives of the labor union. Based on those guidelines, we implement various initiatives, including the introduction of safety and health management systems.



Meeting for persons in charge of environmental measures (Thailand)



Simulated safety training

Leveraging technology and knowledge built up over the years, the NLM Group creates high value added products and services.

The NLM Group seeks to create one-of-a-kind value by multiplying its culture of innovation with the fundamental value of aluminum.

Aluminum Value

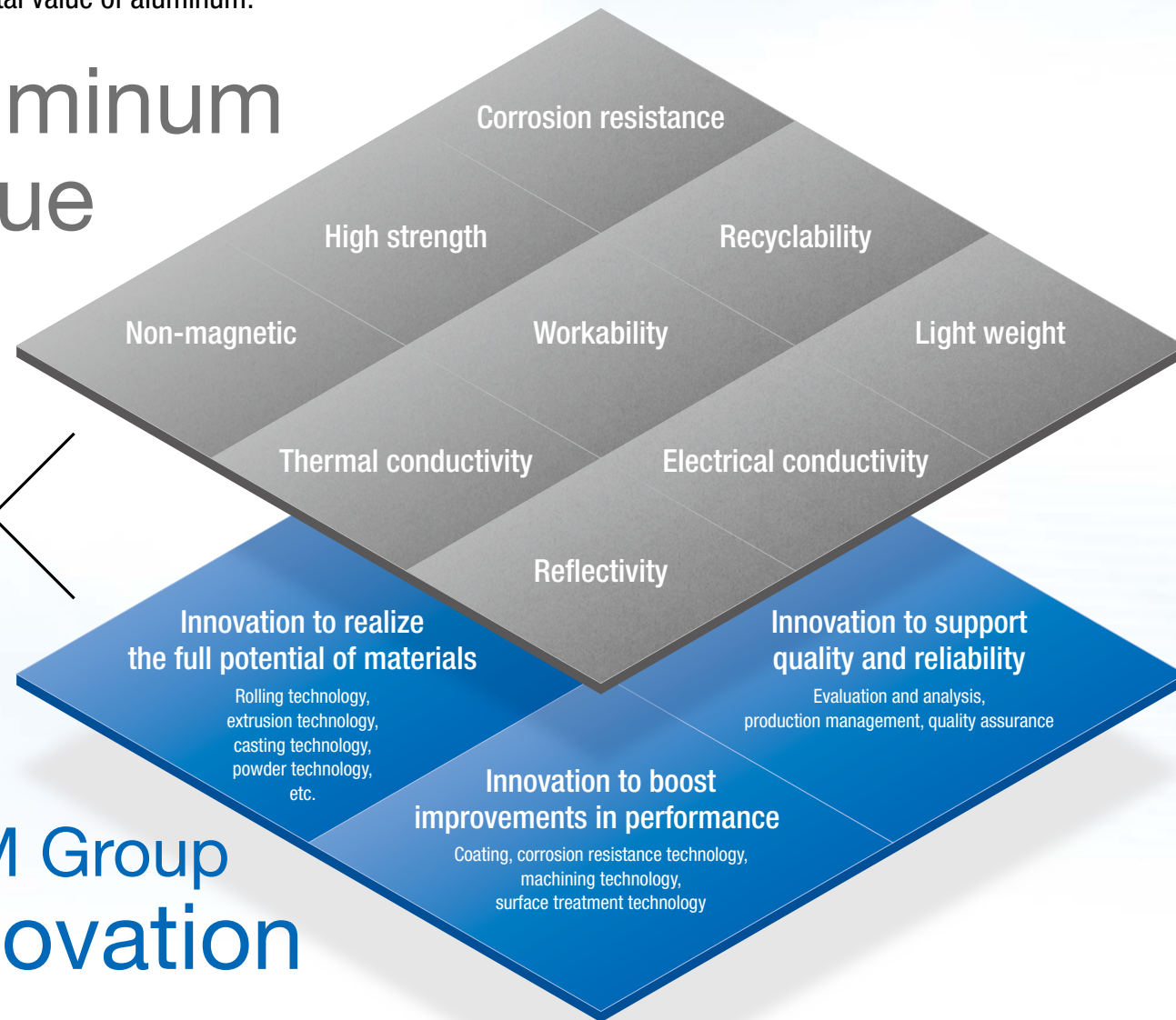

NLM Group Innovation

Spotlight

Recycling Aluminum for a Sustainable Society

Compared to other metals, aluminum does not corrode very easily. Also, since it has a low melting point, it is very easy to melt for recycling. In fact, recycling aluminum is very energy efficient, taking only 3% of the energy needed to manufacture new aluminum ingots.

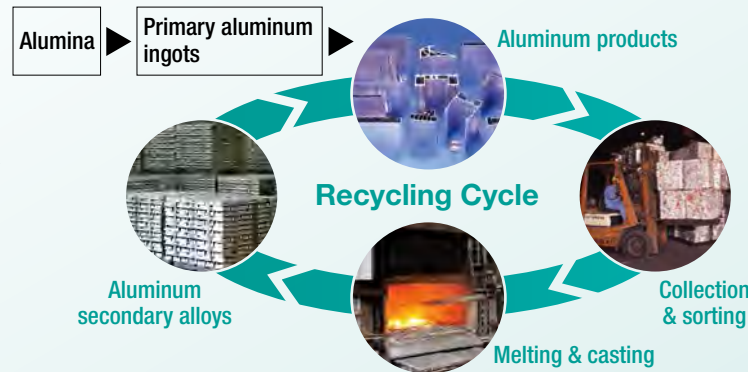

Advanced R&D Centers

With its various R&D centers leading the way, the NLM Group enthusiastically welcomes the challenge of creating new value.

Nippon Light Metal Company Nikkei Research and Development Center

This is the overall NLM Group R&D center that supports horizontally integrated development by effectively applying the innovative technologies possessed by each group company. This center is focused on realizing products that meet customer needs to create new business opportunities.



Nippon Light Metal Company Shimizu Plant, Kambara Chemical Plant

This company does chemical R&D directly at its plants. The Shimizu Plant is equipped with the highest level of aluminum hydroxide related technology in Japan, enabling speedy development. The Kambara Chemical Plant works on new product development such as caustic sodas, all varieties of inorganic compounds, and chlorinated organic compounds.



Toyo Aluminium Core Technology Center (CTC/TEC)

The Core Technology Center (CTC) conducts research and development of new technologies and new products for the creation of new business. The Technical Solution Center (TEC) provides services for the commercialization of R&D products. As the core of the NLM Group's R&D organization, these two research departments strive to develop unique technology and products.



High Level Fabrication Technology

The NLM Group possesses distinctive fabrication technology that makes the most of materials and adds even more value.

Welding

The skilled technicians of Nikkei Metal's Inazawa Plant perform high precision welding at the millimeter level that even machines cannot reliably do. Working with MIG and TIG welding, they also support products in need of spot welding and FSW (friction stir welding) for very thick sheets of metal.

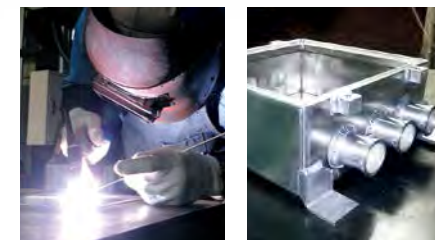

High Precision Fabrication

Nikkei Technology Center performs high precision fabrication using unique technologies related to brazing, cutting, welding, assembly, rigging, and so on. The center obtained JIS Q 9100 certification in 2014 and also manufactures products for aerospace and military defense.



Surface Treatment

Toyo Rikagaku Kenkyusho applies the metal surface treatment technology it has fostered since the beginning to bring out the maximum beauty and functionality of metal. Some of its original technology includes color anodizing aluminum, stainless steel and titanium.



If you ever want a small consultation on making a prototype or implementing a development plan, or wish to request testing, inspection, and so forth, first try **Shisaku.com**. (in Japanese only)

Shisaku.com

SEARCH

*Shisaku.com searches a network of 120 of Japan's finest manufacturers to help customers find the right prototype service.

1 Automobiles

The NLM Group leverages its know-how and comprehensive group capacities as a fully integrated aluminum manufacturer to solve multilayered, multifaceted problems.

Electrical and Electronic Components
Aluminum harnesses, water chillers for cooling power modules, heat sinks for LED headlights, etc.

Gas Pedals, Brakes
Brake caliper bodies, etc.

Climate Controls
Parallel flow sub-cooled condensers for automobile HVACs, etc.

Body Structure and Exterior Components
Bumper reinforcement, etc.

Interior Components
Seat slide rails, etc.

Paint
Aluminum paste, etc.

Power Controller Unit
Aluminum nitride powder, etc.

Engine & Powertrain
Engine mount brackets, intercooler pipes, etc.

Suspension & Wheels
Suspension components, etc.

Bumper reinforcement

Seat slide rail

Engine mount bracket

Intercooler pipe

Water chillers for cooling power modules

Heat sinks for LED headlights

» Products

For Sensors, Honeycomb, Plugs



Alumina for ceramic materials

Nippon Light Metal (Chemicals Div.)

Alumina created using powder manufacturing technology that enables tailoring for the necessary properties for ceramic applications

For Sunroof Guiderails



Sunroof guiderail materials

Nikkeikin ACT

Superior products in terms of quality and cost competitiveness, used in a wide variety of automobiles throughout Japan, Europe, China, and North America

For Wire Harnesses



Aluminum wire harnesses for automobiles

Nippon Light Metal (Metal Alloy & Industrial Parts Div.)

Aluminum alloy wires with superior strength and bend tolerance to meet the need for weight reduction to improve fuel efficiency

For Paint



Metallic pigment Alpaste®

Toyo Aluminium

Aluminum pigments with coin-shaped particles for a smooth surface, with high design functionality, used as the topcoat for automobiles

For Suspensions



Suspension components

Nikkeikin ACT

Each component's shape is designed and tested using optimized methods for manufacturing in terms of material selection as well as developed alloys, extrusion, and forging

For Engine & Drivetrain Systems



Abrasion resistance aluminum alloy NH41

Nikkei MC Aluminium

Aluminum alloys that are easy to handle and have abrasion resistance, which can reduce operating costs in the manufacturing of components

An example of processing by one of our clients

For Brakes



Brake caliper bodies

Nippon Light Metal (Metal Alloy & Industrial Parts Div.)

Integrated caliper body castings using original technology employing aluminum pipe inset casting

For HVACs

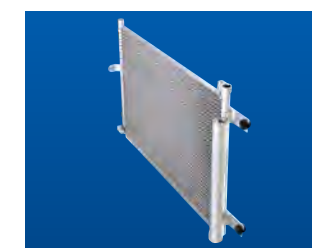

IPFC (parallel flow sub cooled condensers) for automobile HVACs

Nippon Light Metal (Heat Exchanger Div.)

Nikkei Heat Exchanger

All aluminum condensers with superior thermal conductivity, strength and corrosion resistance due to original aluminum material development

» Solutions

Making the most of comprehensive Group capacities to find solutions to advanced problems in automobile development

NLM Group

In recent years, developed countries have further strengthened CO₂ emission regulations, which in turn has increased the need for weight reduction of automobiles. As such, aluminum has been highlighted as an ideal solution for achieving weight reduction since it has one third the specific gravity of steel and copper.

In these market conditions, the NLM Group has been leveraging its integrated system spanning materials, manufacturing, design, and evaluation to provide products that are optimized for the needs of its customers.



Spotlight

Adoption of the Unique Fabrication Process of FLEXCASTER™ to Transform Liquid Aluminum Directly into Sheet

Nippon Light Metal (Rolled Products Div.)

FLEXCASTER™ is a leading edge, high volume, continuous casting technology which can transform liquid aluminum into high quality coils of thin sheet in a single operation. Compared to the conventional method using the same chemical composition, this new method achieves 15% more strength and the same level of deep drawing performance as steel.

Automobile hood inner material (plate material made using FLEXCASTER™)



The world's first motorcycle brake caliper made using high-speed casting

Nikkei Matsuo

Brake calipers are critical safety components. As such, a high level of internal quality is a mandatory characteristic for ensuring the necessary capacity to withstand pressure, functionality, and rigidity. Traditionally, a gravity casting method is used for this application, but the NLM Group successfully mass-produced the world's first motorcycle brake caliper using a high-speed casting method leveraging its proprietary die casting technology (PFDC) and an originally developed alloy. Compared to the products made using the conventional method, the result is a lighter product, which higher design flexibility. The response to this product in the market has been very favorable.



Motorcycle brake caliper

Machinery, Electronics, and Communications

Since aluminum is superior due to its light weight, thermal conductivity, electrical conductivity, and strength, the demand for it is ever increasing as products continue to evolve and become more advanced.

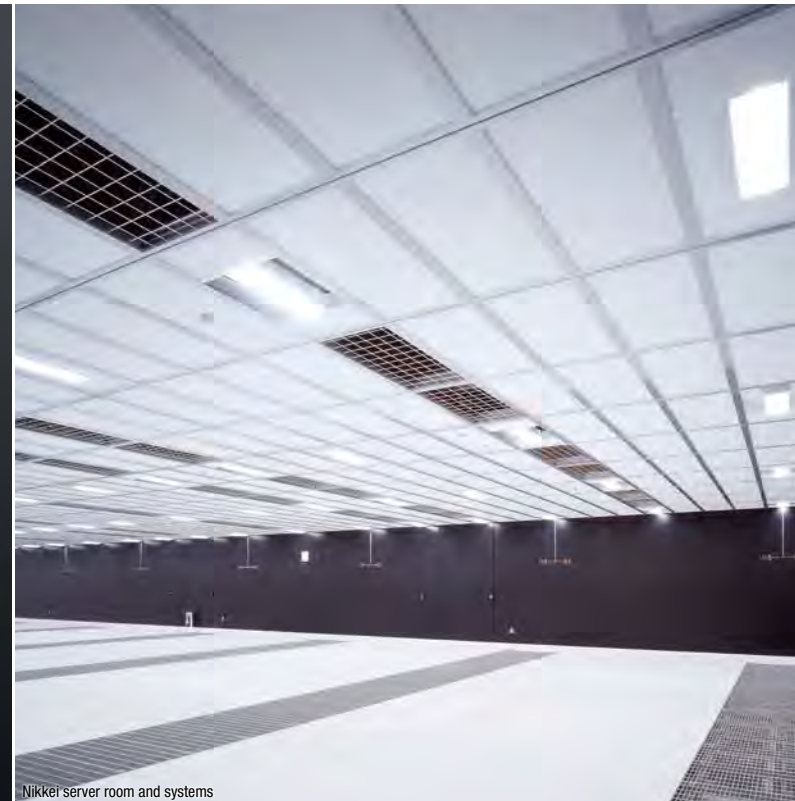

Nikkei server room and systems

» Solutions

Solving serious heat challenges by leveraging comprehensive strengths as an aluminum manufacturer

Nippon Light Metal (Heat Exchanger Div.)	Nikkeikin ACT	Nippon Light Metal (Metal Alloy & Industrial Parts Div.)
Nippon Light Metal (Chemicals Div.)	Nikkei Matsuo	Toyo Aluminium

Electronics are indispensable to contemporary trends such as the electrification of cars and the acceleration of communication networks. They need to achieve a high level of performance, which in turn can present a serious design challenge when it comes to implementing heat countermeasures. The NLM Group is addressing this need by developing optimum heat solutions that make the most of its analysis, design, and manufacturing technologies.

The NLM Group delivers heat solutions by employing its materials, processing, and a wide range of other technologies.

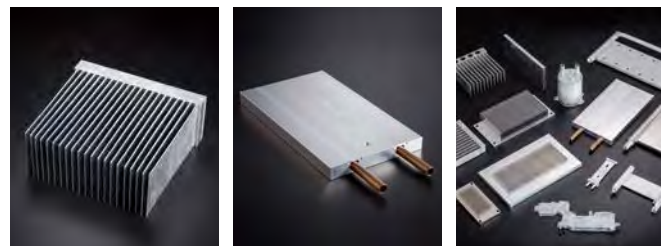

High tongue extrusion heat sinks | Pipe embedded cold plates | An example of a product with heat countermeasures

» Solutions

Supporting equipment for the information networks that are indispensable to society

Nikkeikin ACT	Nikkei Panel System	NLM ECAL
Nikkei Sangyo		

The NLM Group supports the environmental equipment used for information networks by designing and delivering communication-related products that are lightweight, rigid, and have other necessary characteristics.



Nikkei server room and systems | Aluminum double flooring

» Products

For Electronics



Etching circuit foil for IC cards

Toyo Aluminium

Etching circuit foil that provides high functionality to contactless banking and public transportation IC cards

For Electronics



Aluminum electrolytic capacitors

Nippon Light Metal (Capacitor Foil Div.)

Aluminum electrolytic foil, which is the main material in aluminum electrolytic capacitors, jointly developed with Japan Capacitor Industrial Co., Ltd., the top manufacturer in the field of capacitors

For Mobile Devices



High quality anodized sheets

Nippon Light Metal (Rolled Products Div.)

Anodized sheets with a non-yellowing color tone and a very high level of quality that is so stable that it dramatically improves yield rate

For Mobile Devices



High purity alumina for sapphire boards

Nippon Light Metal (Chemicals Div.)

High purity alumina lineup made by improving the refining process of alumina as much as possible, for applications including LED boards and mobile phone cover glass

For Electronics

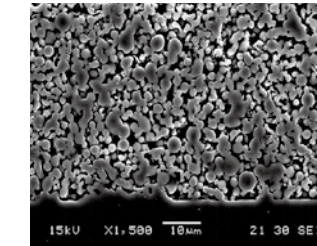

Powder laminated foil

Toyo Aluminium

A laminated material created by sintering aluminum foil and powder together to form a porous body with a large amount of surface area

For Digital Office Automation Equipment



Polygon mirrors & photoreceptor drums

Nikkeikin ACT

Cutting tubes for high precision photoreceptor drums and materials for polygon mirrors used to realize the high reflectivity needed in laser printers and other digital office automation equipment

For Electronics



High conductivity plate material and components

Nippon Light Metal (Rolled Products Div.)

A full lineup of products to meet the demand for conductivity and strength, available in various made-to-order surface treatments (plating, conductive grease application) to reduce contact resistance

For Mobile Devices



Photoluminescent alumite die-cast alloys

Nikkei MC Aluminium

Beautifully colored die-cast aluminum alloys produced using anodizing

Spotlight

Development of Hybrid Aluminum/Resin Manufacturing Technology

Nippon Light Metal (Rolled Products Div.)

Aluminum possesses the properties of heat dissipation, conductivity, and heat absorption. Resin possesses the properties of thermal insulation and chemical resistance. The NLM Group has developed the technology to join aluminum and resin to successfully manufacture an aluminum-resin hybrid. We anticipate such applications as smartphone chassis.



Hybrid product (smartphone chassis prototype)

Aluminum with the Highest Level Purity in the World

Nippon Light Metal

The NLM Group produces high purity aluminum at the world-class 6N level (99.9999% pure) using industrial production techniques to meet a variety of customer needs.



High purity aluminum

Business Field 3

Environment, Safety, and Energy

The NLM Group contributes to safety and preservation of the environment in a variety of ways using its group-wide technical development capacities to make the most of the innate characteristics of aluminum in environmental applications.



Photo provided by NAC International

Photo provided by ORANO TN International

Photo provided by ORANO TN International

» Solutions

Expanding renewable energy with ALSOLMEGA®

Nippon Light Metal	NLM ECAL	Nikkeikin ACT
Sumikei-Nikkei Engineering	Nikkei Extrusions	Nikkei Sangyo
Riken Light Metal Industry	Toyo Tokai Aluminium Hanbai	Nikkei Metal

Solar panel frames are indispensable to implementing solar power generation. However, the conventional method involving heavy steel has been a problem in terms of construction difficulties as well as the load on installation structures. In response, the NLM Group has developed and commercialized a superlight solution that is about one-third the weight of traditional steel solar panel frames. It yields a variety of benefits: better construction performance, lower logistics costs, shorter lead time, longer life, installation location flexibility, and more.



» Solutions

MAXUS® and NEXUS-3000® neutron absorber materials for both spent fuel pool racks and dry storage casks

Nikkeikin ACT	Nippon Light Metal	Toyo Aluminium
---------------	--------------------	----------------

MAXUS® and NEXUS-3000® are MMC materials created by mixing aluminum powder with boron carbide powder, which absorbs neutrons. Mass production of these high-performance materials was made possible by the collective knowledge and know-how of each NLM division and the powder technology of Toyo Aluminium. These products meet customers' expectations because we produce Al-B4C MMC materials with the neutron absorption capacity required for spent fuel pool racks and dry cask baskets.

MAXUS® NEXUS-3000®

● Images of dry cask baskets

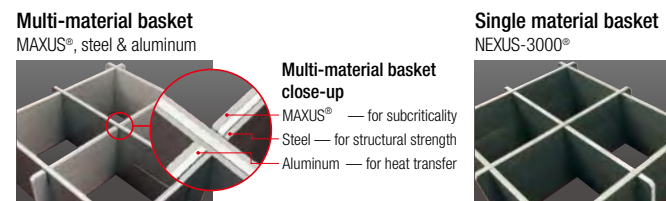

» Products

For Solar Cells



ToyalSolar®

Toyo Aluminium

A backsheet material for solar cell modules, recognized by manufacturers around the world for its ability to dramatically improve the life of solar cell modules

For Solar Cells



Lightweight solar cell module

Toyo Aluminium

A solar cell module that is half the weight but delivers the same performance as conventional ones, which can be installed in difficult places like carport rooftops, warehouses, walls of buildings and large facilities

For Anodizing Factories and Printing Plate Factories



Alkali collection device

Nikkei Sangyo

A device that separates caustic soda and crystalline aluminum hydroxide from the caustic waste that results during the etching process of aluminum surface treatment so that those substances can be reused

For Disaster Prevention Equipment



Water supply tank

Nikkeikin ACT

A water supply container used for water during disasters, foldable for improved storability and very hygienic with the use of an inner lining

For Disaster Prevention Equipment



Disaster prevention storage shed

NLM ECAL

Disaster prevention storage sheds that are very reliable for long-term storage of physical goods, including some solar-powered models

For Soil



Aluminum chloride hexahydrate

Nippon Light Metal (Chemicals Div.)

Aluminum chloride hexahydrate for spreading on soil to control the soil's acidity

AlCl₃·6H₂O

For Seismic Motion Control



BRACEREE®

Nikkeikin ACT

An aluminum brace that is capable of reducing seismic motion in wooden houses during an earthquake using an aluminum hysteretic damper to absorb energy

For Quakeproofing



Quakeproofing reinforcement brace

Sumikei-Nikkei Engineering

Quakeproofing reinforcement implemented using a variety of construction methods to match existing building structures

Spotlight

Nikkei Ecolas: Chrome-Free Colored Aluminum for Better Health and a Cleaner Environment

Nippon Light Metal (Rolled Products Div.)

Up until now, processing agents such as hexavalent chromium have been used in the pre-treatment stages of paint. However, since it became known that hexavalent chromium is highly toxic, world regulations have been enacted to restrict its usage.

In response, the NLM Group developed Nikkei Ecolas, a chrome-free colored aluminum which complies with ELV, WEEE, RoHS, and other such standards, and completely avoids the use of chrome, lead, and other materials and agents that negatively impact the environment.



Nikkei Ecolas, used on a truck

Public Works, Landscape, Construction

The NLM Group contributes to better energy savings and durability in safe, secure, and comfortable spaces for everyday life, which feature both excellent product function and superior design.



» Solutions

Japan's first-ever aluminum floor systems for road bridges meet the need for weight reduction

Nikkeikin ACT Nippon Light Metal Nikkei Sangyo

In recent years, an increasing number of aging bridges in Japan are reaching the point where they must be replaced. Nikkeikin ACT and the Nikkei Research and Development Center have been taking the lead in developing aluminum floor systems for road bridge applications. These systems, lightweight and with a high level of fatigue durability, scored a success when the first application in Japan came in at about one-fifth the weight of traditional concrete floor systems.



Road bridge employing aluminum floor slabs

● Friction Stir Welding (FSW) technology for high strength joints

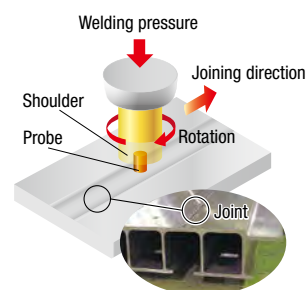

● Features of aluminum floor slabs for road bridges

Lightweight	High corrosion resistance	High durability
Prefabricated structure		Reduction of maintenance costs

» Solutions

Continuing to expand the potential of aluminum by applying time-tested technologies to new applications

Nippon Light Metal Nikkei Sangyo

NLM proposed a new construction method that utilizes flat multi-hole pipes made from extruded aluminum with excellent thermal conductivity. It enables airtight structures to be built at construction sites with no upper limit on size.



Aluminum flat multi-hole pipe



Construction example of an ice skating rink

» Products

For Building Structures



ALMISSIMO aluminum finishing material with sound absorbing function for indoor applications

Riken Light Metal Industry

An interior aluminum material that absorbs noise for a more comfortable environment, employed at stores that require quietness

For Public Spaces



Comprehensive development for train station surroundings

Sumikei-Nikkei Engineering

Proposed for optimized facilities that are integrated into the environment and which provide nice landscaping for pedestrian decks, shelters, etc

For Paint



Stenshel® SABIKONA-ZU

Toyo Aluminium

Paint incorporating high-quality stainless steel flakes to create a tough coating that is highly durable and very rust-resistance; can help reduce the overall painting process, saving both time and money in construction

For Refrigerators/Freezers (commercial)

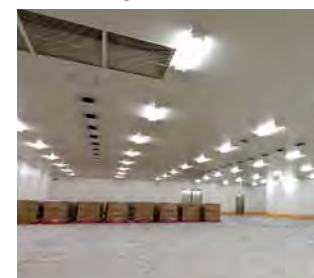

Thermal insulation panels for refrigerators and freezers

Nikkei Panel System

Panel systems for refrigerators and freezers that enable precise temperature control and meet the needs of HACCP and the globalization of food distribution

For Power Equipment



Environmental harmonious aluminum soundproof wall panel

Nikkei Extrusions

Panels which deliver superior deep bass noise-proofing in protection barriers used in power equipment, etc., employed at integrated production plants to reduce noise, dust and other such problems at worksites

For Bridges



KERO aluminum alloy path for bridge inspections

Sumikei-Nikkei Engineering

An aluminum inspection path for inspecting bridge girders, etc., made of aluminum alloy with superior corrosion resistance and light enough to install on existing bridges

For Buildings (interior and exterior design)



Interior/exterior louvers

Riken Light Metal Industry

A lineup of a wide array of design louvers for use as blinds, light shielding, ventilation, and even construction design

For Buildings (ceilings)



NEQRES series of quakeproof ceilings

Nikkei Panel System

Ceilings using compression braces that deliver twice the design bearing force of conventional braces, resulting in lower brace volume and material costs and more effective use of ceiling space

Spotlight

GENESTA Incombustible: CFC-Free Thermal Insulated, Incombustible Panels Designed for Environmental Performance



Nikkei Panel System

GENESTA Incombustible is a CFC-free, thermal insulated panel that is environmentally friendly because it has zero negative impact on the ozone layer and almost no negative impact on global warming. The panel is the result of a world-first application*1 of HFO.*2 It has great environmental performance, is certified as a fire prevention material, and meets the needs of food plants, refrigerators, and freezers.

*1: World's first application for injected foam metal sandwich panels (Source: Nikkei Panel Systems' research)

*2: HFO (hydrofluoroolefin)

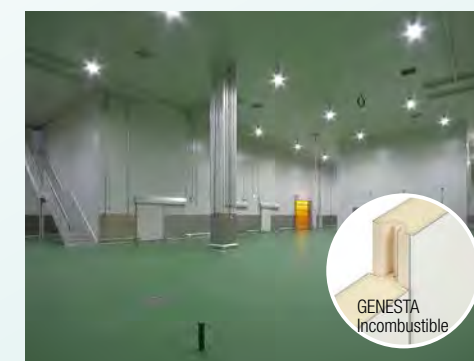

GENESTA Incombustible in use at a food processing plant

Transportation

The NLM Group is focused on developing products that make the most of the properties of aluminum with the Group's original fabrication technology to meet needs in many transportation fields, including *shinkansen* bullet trains.

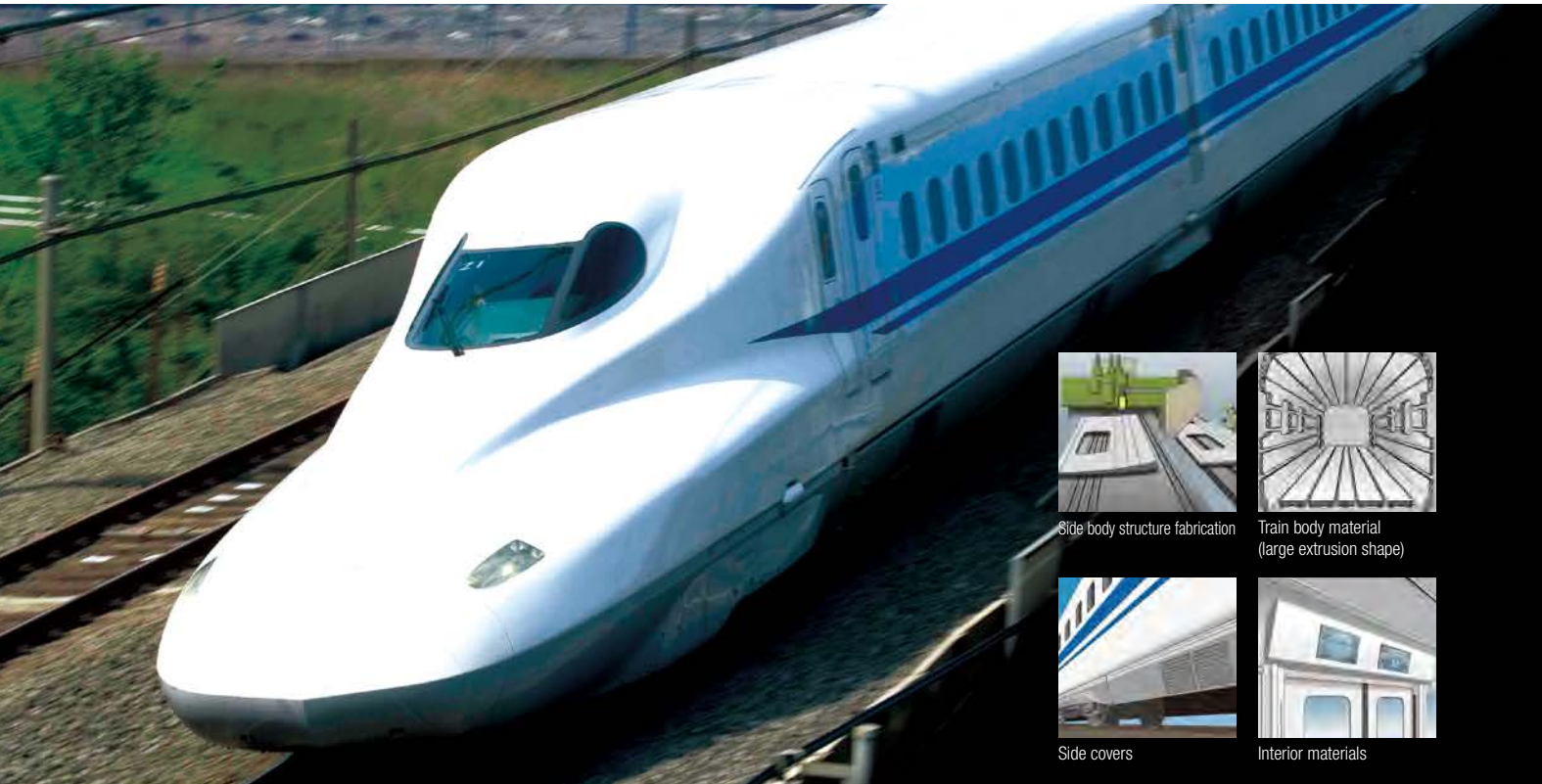

» Solutions

Developing technologies to contribute to improvement of both the environmental performance and comfort of trains

Nikkeikin ACT

Nippon Light Metal (Rolled Products Div.)

In order to support the high speeds at which today's bullet trains travel, the materials used have to be both light and strong. In response, the NLM Group uses some of the best large-scale, hollow extrusion manufacturing technology in Japan to develop and manufacture aluminum alloy double skin structural material that is both light and very strong, used for the backbone. This double skin structural material has a truss shape section formed using a combination of triangular shapes.

Our solution has been adopted for the Tokaido, Sanyo, Tohoku, and Hokuriku *Shinkansen* bullet train lines. Our original technology and know-how has also contributed to the realization of all aluminum cars for some trains on other lines.



High precision extrusion technology

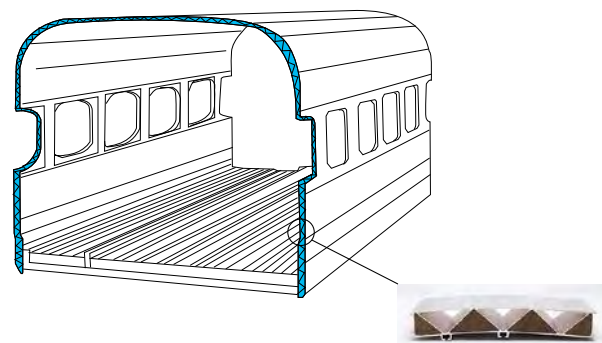

Aluminum alloy double skin structural material

» Products

For Freight Transportation



Vans

Nippon Fruehauf

A wide range of vans, from large to small, all watertight and efficient for carrying and handling

For Freight Transportation



Wing roof

Nippon Fruehauf

Wing roof perfect for large items due to high handling efficiency

For Freight Transportation



Temperature controlled vans

Nippon Fruehauf

A lineup of vans with fantastic features such as CFC-free, thermal insulating materials and CHILNO, an original chiller unit

For Freight Transportation



Trailers

Nippon Fruehauf

A full lineup of everything from van trailers to container chassis, as well as wing trailers to full trailers

For Freight Transportation



Containers

Nippon Fruehauf

Containers that meet the needs of the modal shift to train and other freight transport systems

For Freight Transportation



Power-saving devices

Nippon Fruehauf

Tailgate lifters and various other power-saving devices that improve the efficiency of cargo handling work

For Freight Transportation



Hinged drop sides for loading onto trucks

Nikkeikin ACT

Enclosures for preventing objects from falling off the bed of the truck; featuring hinged drop sides that are very strong, light and durable so that truck beds can be widely used; can be installed on wing roof vehicles, as well

For Transportation



Fuel tanks

Nikkeikin ACT

Aluminum fuel tanks for trucks that are light, have superior corrosion resistance, and stay clean and good looking over a long period of time

For Transportation



Aluminum bridges

Nikkeikin ACT

Made from high strength aluminum alloy for welding, light and very strong to support the loading and unloading of construction and agricultural machinery

For Cargo Handling & Transportation

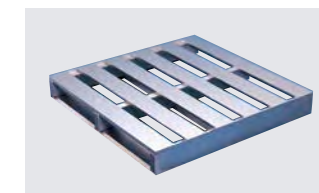

Aluminum pallets

Nikkeikin ACT

Aluminum pallets that do not build up static electricity and are very sanitary, used in a wide variety of logistics fields

Spotlight

Bulk Transport 21-meter Center Axle Full-size Trailer

Nippon Fruehauf

Yamato Transport Co., Ltd., the largest courier service in Japan, introduced a 21-meter full size trailer in Japan in 2016 for transportation between Higashi-Meihan terminals. This vehicle was a joint development between Isuzu Motors Limited and Nippon Fruehauf. Since the introduction of this new trailer, transportation volume has increased by 23% over conventional trailers, and this is helping to improve transportation efficiency and CO₂ reduction.



Yamato Transport's 21-meter center axle full-size trailer

Food, Health & Industrial Products

The NLM Group offers customer-oriented product ideas that are helpful in daily life for food, health, and industrial fields. These products are made from highly functional materials and are designed with full consideration for the environment.



» Products

For Pharmaceuticals



READ-MAX®
Toyo Aluminium
Aluminum foil for pharmaceutical tablet packaging that can be read by bar code readers without requiring the customary white background

For Food



Aluminum can and dispenser cleaning can
Nippon Light Metal (Container Div.)
Originally developed large three-liter beer cans manufactured using drawing and ironing techniques

For Food



Thermal insulated panels for food processing plants
Nikkei Panel System
Non-flammable, high thermal insulated panels that reduce the risk of contamination and cross-contamination

For Various Industries

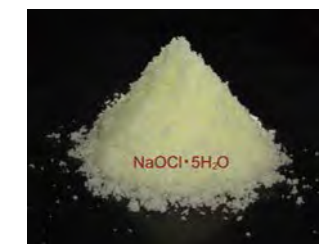

Fungicide and industrial oxidizer
Nippon Light Metal (Chemicals Div.)
Nippon Light Metal was the first in the world to industrialize solid sodium hypochlorite. It is used as a fungicide for food and drinking water and as an oxidizing agent in various organic synthesis reactions.

For Food, Medical & Industrial Materials



TOYAL LOTUS® water-repellent packaging
Toyo Aluminium
Developed originally for the inside of yogurt container lids to keep the yogurt from sticking to the lid; currently working to expand into other applications

For Food & Packaging



TD series of printing ink
Toyo Aluminium
Non-toluene type of aluminum pigment made using propyl acetate and ethyl acetate and other solvents, safe for the environment

For Cosmetics



Cosmicolor®: Aluminum pigment with interference color
Toyo Aluminium
Pigment in which the reflection of light from the plating layer and aluminum flakes interfere with each other to make the hue change with the angle of view

For Industrial Goods



Carbon blocks for blast furnaces
Nippon Electrode
The No.1 brand in the world thanks to high quality, high precision and a long life of over 20 years, used worldwide in large blast furnaces

Spotlight

Light, easy-to-carry, easy-to-assemble aluminum cycle stand for sport bicycles

Riken Light Metal Industry

This aluminum cycle stand is light and easy to assemble. It is adjustable from 1,150 mm to 1,700 mm, making it possible to hold up to five bicycles. Great for convenience stores, bicycle shops, coffee shops along cycling paths, race venues, ride event venues, hotels, etc. It also folds and comes with an exclusive storage bag, making it easy to carry.



NLM Group Products Playing an Active Role in the Field of Sports

Nikkeikin ACT

NLM Group products play an important role in many different fields of activity, including the sports field. At the 2002 FIFA World Cup soccer tournament, jointly hosted by Japan and South Korea, seven of the ten stadiums used soccer goals made by Nikkeikin ACT. In recent years, the NLM Group has also been offering alloys developed for use in baseball bats.



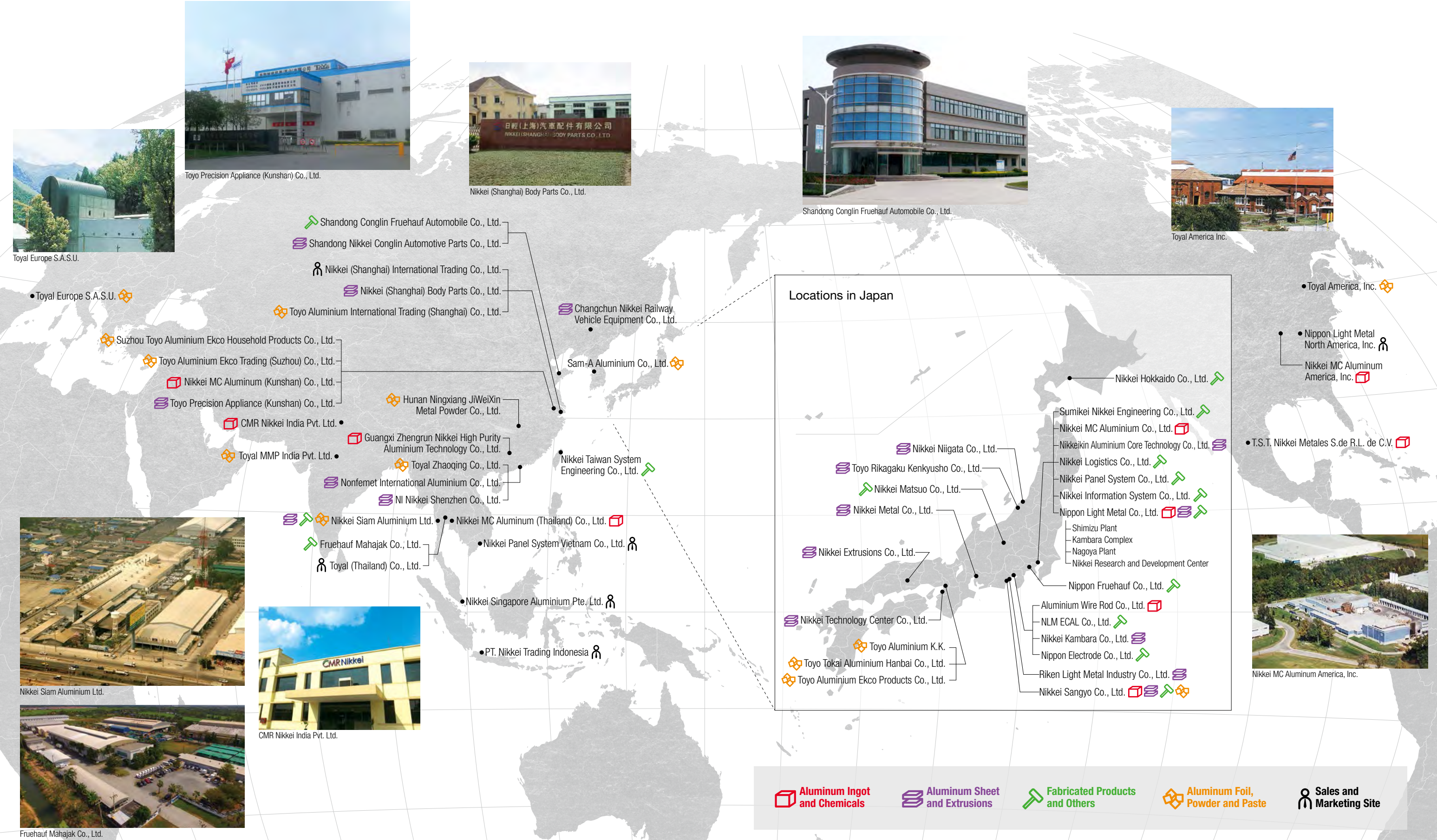

The NLM Group's Global Reach

The NLM Group is broadening its worldwide presence to keep pace with the globalization of its customers.

Corporate Profile

Trade name Nippon Light Metal Holdings Co., Ltd.

Headquarters 2-2-20 Higashi-shinagawa, Shinagawa-ku, Tokyo 140-8628 Japan

Date of establishment October 1, 2012

Capital 46,525 million yen

Sales 481,439 million yen (consolidated)

Employees 12,855 (consolidated)

*The data shown above is for fiscal 2017, or current as of the end of March 2018.

Executives (As of June 26, 2018)

Directors

President and CEO	Ichiro Okamoto	Director	Kotaro Yasuda
Director	Toshihide Murakami	Director	Toshikazu Tanaka
Director	Yasunori Okamoto	Director	Masato Ono ¹
Director	Hiroshi Yamamoto	Director	Ryoichi Hayashi ¹
Director	Hiroyasu Hiruma	Director	Haruo Ito ¹
Director	Sho Adachi	Director	Toshihito Hayano ¹
Director	Yoshihiro Tomioka		

¹ Outside director

Audit & Supervisory Board Members

Audit & Supervisory Board Member	Nobuo Matsumoto
Audit & Supervisory Board Member	Takayuki Tsuchida
Audit & Supervisory Board Member	Koji Fukui
Audit & Supervisory Board Member	Yuzuru Fujita ²
Audit & Supervisory Board Member	Koji Yasui ²
Audit & Supervisory Board Member	Shintaro Kawai ²

² Outside member

Officers

Officer	Takashi Hara
Officer	Masamichi Ueda
Officer	Minoru Sotoike
Officer	Hideki Amimura
Officer	Kazuto Sanada
Officer	Masato Saotome
Officer	Masakazu Ichikawa

NLM Group Management

(As of June 2018)

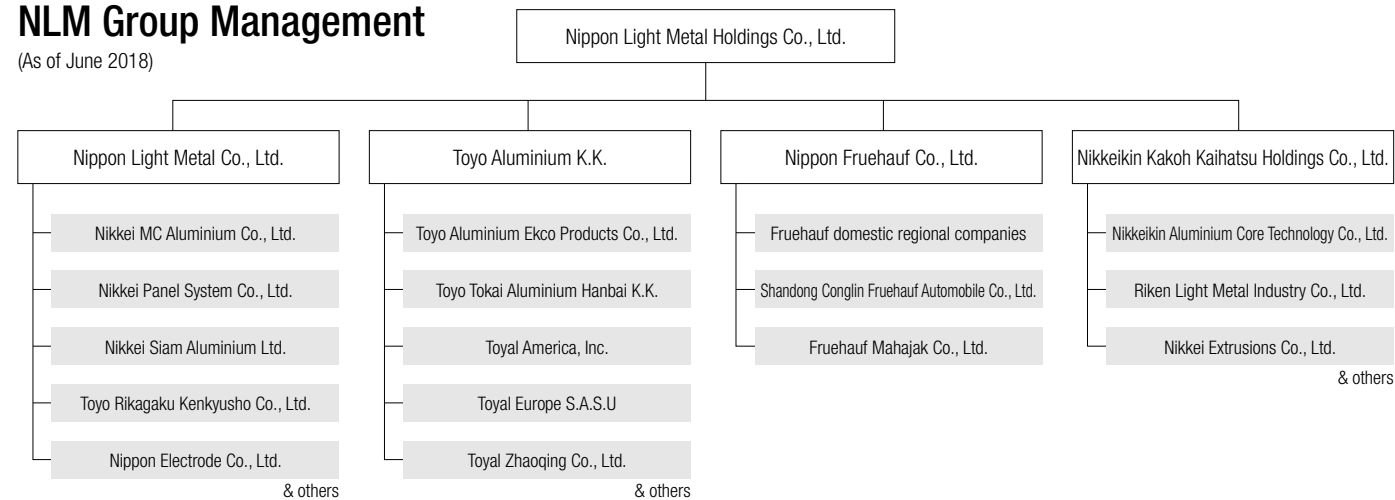

Consolidated Business Performance

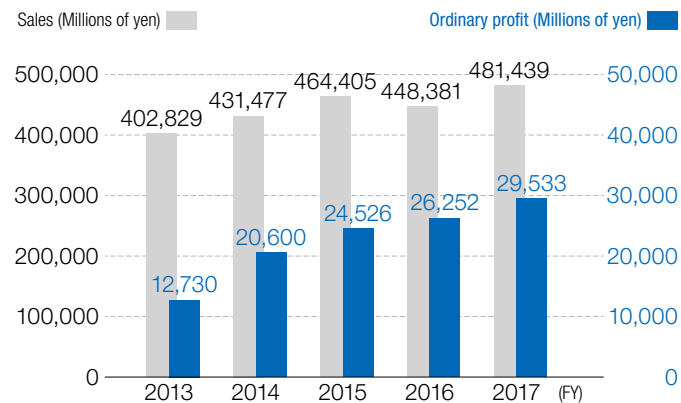

Composition of Consolidated Sales

(Fiscal 2017)

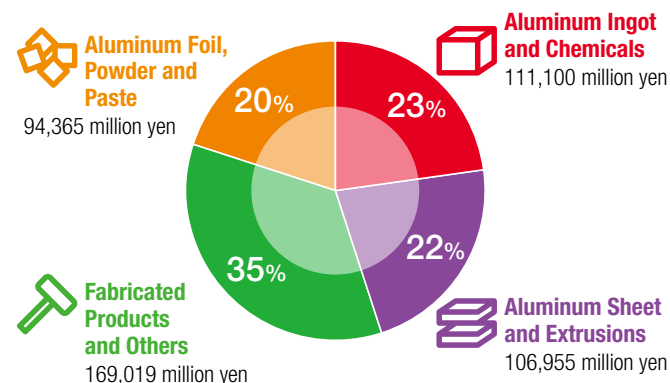

Corporate History

1939 ▶▶ First Founding

- 1939 · Nippon Light Metal Co., Ltd. incorporated jointly by Furukawa Electric Co., Ltd., and Tokyo Dento (currently TEPCO) to start aluminum smelting.
- 1940 · Aluminum smelting at Kambara Plant (currently Kambara Complex) started.
- 1941 · Aluminum production at Shimizu Plant started.
- 1945 · Nippon Electrode Co., Ltd. established.
- 1949 · Listed on the Tokyo Stock Exchange.

1952 ▶▶ Second Founding & Progress

- 1952 · Capital and technology cooperation with Aluminium Limited (currently Rio Tinto Alcan Inc.) of Canada established.
- 1962 · Nikkei Building (former headquarters building) completed in Ginza, Tokyo.
- 1963 · Technical ties with Fruehauf International Limited of the U.S. started. Nippon Fruehauf Co., Ltd. established.

1974 ▶▶ Fabrication Business Development

- 1974 · Merger with Nikkei Aluminium Co., Ltd.
- 1978 · Merger with Nikkei Aluminium Rolling Co., Ltd.
- 1984 · NLM Group construction material business integrated to establish Shin Nikkei Co., Ltd.
- 1985 · Nikkaru Extrusion Co., Ltd. merged into Nippon Light Metal Co., Ltd. (currently Nikkei Kambara Co., Ltd.).
- 1986 · Sales division of NLM Group's construction material department merged into Shin Nikkei Co., Ltd.
 - Nonfemet International Aluminium Co., Ltd. established in Shenzhen, China.
- 1989 · Nikkei Kako Co., Ltd. merged into Nippon Light Metal Co., Ltd.
- 1991 · Taishin Light Metal Co., Ltd. merged into Nippon Light Metal Co., Ltd.
- 1995 · Nikkei Techno-Research Co., Ltd. merged into Nippon Light Metal Co., Ltd. Nikkei Research and Development Center (NRDC) established.
- 1996 · NLM headquarters moved to Higashi-shinagawa, Shinagawa-ku, Tokyo.
 - Capital participation in Toyo Aluminium K.K. initiated.
- 1999 · Toyo Aluminium K.K. merged into Nippon Light Metal Co., Ltd.
- 2000 · Nikkei Shoji Co., Ltd. merged into Nikkei Sangyo Co., Ltd.
 - Shin Nikkei Co., Ltd. established as a 100% subsidiary.
- 2002 · Panel system division separated to establish Nikkei Panel System Co., Ltd.
 - Extrusion and light pressure fabricated products division (except Container section) separated to establish Nikkeikin Aluminium Core Technology Co., Ltd.
 - Toyo Aluminium division merged into Toyo Aluminium K.K.

2003 ▶▶ Global Business Development

- 2003 · Alcan Nikkei Siam Ltd. (currently Nikkei Siam Aluminium Ltd.) established as consolidated subsidiary.
- 2004 · NI Nikkei Shenzhen Co., Ltd., a company for fabrication and sales of aluminum extrusion products for automobile parts, established jointly with Nonfemet International Aluminium Co., Ltd.
- 2005 · M.C. Nikkei Aluminium (Kunshan) Co., Ltd. (currently Nikkei MC Aluminium (Kunshan) Co., Ltd.) established.
- 2007 · Casting and die casting business merged with M.C. Aluminum Co., Ltd., a subsidiary of Mitsubishi Corp., to establish Nikkei MC Aluminium Co., Ltd., later becoming subsidiary.
 - Toyal Zhaoqing Co., Ltd. established in Zhaoqing, China by Toyo Aluminium K.K.
- 2008 · Nikkei (Shanghai) Body Parts Co., Ltd. established in Shanghai, China.
- 2010 · All shares of Shin Nikkei transferred to JS Group Corporation (currently LIXIL Group Corporation).
 - Nikkei (Shanghai) International Trading Co., Ltd. established in Shanghai, China.
- 2011 · Nikkeikin Kakoh Kaihatsu Holdings Co., Ltd., an intermediate stock holding company, established to control the group's extrusion and extrusion process business.
- 2012 · Nippon Light Metal Holdings Co., Ltd. established as a pure holding company for the Group.
 - Completion of raw materials shift from bauxite to aluminum hydroxide at Nippon Light Metal's Shimizu Plant.
- 2014 · Nippon Light Metal Co., Ltd. discontinues its electrolytic aluminum smelting business.
- 2015 · Toyo Rikagaku Kenkyusho becomes a subsidiary.

List of Major Group Companies

Nippon Light Metal Holdings Co., Ltd.

2-2-20 Higashi-shinagawa, Shinagawa-ku,
Tokyo 140-8628 Japan

Tel: +81-3-5461-8601

Business content: Management and control of subsidiaries and all activities incidental or related thereto.

Group Business

- Manufacture and sale of alumina, aluminum hydroxide, various chemicals, and aluminum ingots/alloys
- Manufacture and sale of aluminum rolled products and aluminum extrusion products
- Manufacture and sale of transportation-related products, electronic materials, aluminum fabricated products such refrigerator/freezer panels, and carbon products, as well as services such as transportation, information processing, and insurance
- Manufacture and sale of foil and powder products

Aluminium Wire Rod Co., Ltd.

5443 Kambara, Shimizu-ku, Shizuoka City, Shizuoka 421-3203 Japan
TEL: +81-54-388-2662

NLM ECAL Co., Ltd.

161 Kambara, Shimizu-ku, Shizuoka City, Shizuoka 421-3203 Japan
TEL: +81-54-388-3555

Nikkei Technology Center Co., Ltd.

1-11 Nishiki-kitamachi, Kaizuka City, Osaka 597-0092 Japan
TEL: +81-724-23-9235

Sumikei-Nikkei Engineering Co., Ltd.

Shin-ei Building, 2-35-13 Kameido, Koto-ku, Tokyo 136-0071 Japan
TEL: +81-3-5628-8510

Toyo Rikagaku Kenkyusho Co., Ltd.

1961 Somagi, Tsubame City, Niigata 959-1284 Japan
TEL: +81-256-62-5175

Toyo Tokai Aluminium Hanbai Co., Ltd.

Honmachi Yamamoto Building, 4-1-10 Minamihonmachi, Chuo-ku,
Osaka City, Osaka 541-0054 Japan
TEL: +81-6-6245-1071

Toyo Aluminium Ekco Products Co., Ltd.

Orix Honmachi Building, 1-4-1 Nishihonmachi, Nishi-ku, Osaka City,
Osaka 550-0005 Japan
TEL: +81-6-6110-1301

Toyo Aluminium K.K.

Midosuji Daiwa Building, 3-6-8 Kyutaromachi, Chuo-ku, Osaka City,
Osaka 541-0056 Japan
TEL: +81-6-6271-3151

Nikkei MC Aluminium Co., Ltd.

Ueno Building, 2-6-2, Kaji-cho, Chiyoda-ku, Tokyo 101-0044 Japan
TEL: +81-3-5297-5800

Nikkei Extrusions Co., Ltd.

2100 Ochiai-cho-abe, Takahashi City, Okayama 716-0061 Japan
TEL: +81-866-22-6021

Nikkei Kambara Co., Ltd.

161 Kambara, Shimizu-ku, Shizuoka City, Shizuoka 421-3297 Japan
TEL: +81-54-385-4321

Nikkeikin Aluminium Core Technology Co., Ltd.

2-2-20 Higashi-shinagawa, Shinagawa-ku, Tokyo 140-0002 Japan
TEL: +81-3-5461-9392

Nikkeikin OhLiS Co., Ltd.

1-34-1 Kambara, Shimizu-ku, Shizuoka City, Shizuoka 421-3203 Japan
TEL: +81-54-385-4462

Nikkeikin Kakoh Kaihatsu Holdings Co., Ltd.

2-2-20 Higashi-shinagawa, Shinagawa-ku, Tokyo 140-0002 Japan
TEL: +81-3-5461-8310

Nikkei Sangyo Co., Ltd.

5-12 Matsubara-cho, Shimizu-ku, Shizuoka City,
Shizuoka 424-0825 Japan
TEL: +81-54-353-5271

Nikkei Information System Co., Ltd.

2-2-20 Higashi-shinagawa, Shinagawa-ku, Tokyo 140-0002 Japan
TEL: +81-3-5461-8787

Nikkei Niigata Co., Ltd.

1572-19 Taro-dai, Kita-ku, Niigata City, Niigata 950-3101 Japan
TEL: +81-25-255-3141

Nikkei Heat Exchanger Co., Ltd.

161 Kambara, Shimizu-ku, Shizuoka City, Shizuoka 421-3297 Japan
TEL: +81-54-385-2164

Nikkei Panel System Co., Ltd.

2-2-20 Higashi-shinagawa, Shinagawa-ku, Tokyo 140-0002 Japan
TEL: +81-3-5461-1170

Nikkei Logistics Co., Ltd.

RBM Kyobashi Building, 3-4-8 Hacchobori, Chuo-ku,
Tokyo 104-0032 Japan
TEL: +81-3-6222-7720

Nikkei Hokkaido Co., Ltd.

43-3 Harumi-cho, Tomakomai City, Hokkaido 053-0002 Japan
TEL: +81-144-55-7161

Nikkei Matsuo Co., Ltd.

813-1 Asamagahara, Shimonojo, Ueda City, Nagano 386-1211 Japan
TEL: +81-268-38-0001

Nikkei Metal Co., Ltd.

4-20-15 Chiyoda, Naka-ku, Nagoya City, Aichi 460-0012 Japan
TEL: +81-52-331-6261

Nippon Light Metal Co., Ltd.

2-2-20 Higashi-shinagawa, Shinagawa-ku, Tokyo 140-8628 Japan
TEL: +81-3-5461-9211

Nippon Electro Co., Ltd.

5600 Kambara, Shimizu-ku, Shizuoka City, Shizuoka 421-3203 Japan
TEL: +81-54-385-3141

Nippon Fruehauf Co., Ltd.

Headquarters and Atsugi Plant: 3034 Kamiechi-uenohara, Atsugi City,
Kanagawa 243-0281 Japan
TEL: +81-46-285-3111
Tokyo Headquarters: Shinagawa East Building, 1-6-34 Konan,
Minato-ku, Tokyo, 108-0075 Japan
TEL: +81-3-5715-0150

Riken Light Metal Industry Co., Ltd.

3-2-1 Magarikane, Suruga-ku, Shizuoka City, Shizuoka 422-8530 Japan
TEL: +81-54-281-1111

Shandong Conglin Fruehauf Automobile Co., Ltd.

3 North Rd., Conglin Industry Dist., Longkou, Shandong, China
TEL: +86-535-8567976

Shandong Nikkei Conglin Automotive Parts Co., Ltd.

3 North Rd., Conglin Industry Dist., Longkou, Shandong, China
TEL: +86-535-8567839

Toyo Precision Appliance (Kunshan) Co., Ltd.

Headquarters and Plant: 188, Gao Ding Rd. Kunshan Economic &
Technical Development Zone, Jiangsu, China
TEL: +86-512-57812388

Nikkei (Shanghai) Body Parts Co., Ltd.

Suzhou Plant: No.1000 Chunshen Road, Huangdai Town, Xiangcheng
District, Suzhou City, Jiangsu Province, China
TEL: +86-512-6571-0550

Nikkei (Shanghai) International Trading Co., Ltd.

137 Xianxia Rd., Shanghai 200051, China
TEL: +86-21-62369659

Nikkei MC Aluminum (Kunshan) Co., Ltd.

No.8 ShengXi Road, Kunshan Economic Technology Development Zone,
JiangSu Province, China
TEL: +86-512-57631946

Nikkei MC Aluminum (Thailand) Co., Ltd.

78/1 Moo2, Bangna-Trad Highway Km. 36 Wellgrow Industrial Estate
T.Pimpa A.Bangpakong Chachengsao 24180 Thailand
TEL: +66-38-522296

Nikkei Siam Aluminium Ltd.

30 Moo 14, Paholyothin Road, K. M. 47, Tambon Klong 1, Amphur
Klongluang, Pathumtani 12120 Thailand
TEL: +66-2909-7300

Fruehauf Mahajak Co., Ltd.

67/16 Moo.5, Kokfad, Nongchok, Bangkok 10530 Thailand
TEL: +66-2548-3733

Nikkei Panel System Vietnam Co., Ltd.

8th Floor, Dai Minh Convention Tower, 77 Hoang Van Thai St., Tan Phu
Ward, Dist. 7, Ho Chi Minh City, Vietnam
TEL: +84-8-5416-8080

Toyal America, Inc.

1717 North Naper Boulevard, Suite 201, Naperville, Illinois 60563 U.S.A.
TEL: +1-630-505-2160

Nikkei MC Aluminum America, Inc.

6875 South Inwood Drive Columbus Indiana 47201 U.S.A.
TEL: +1-812-342-1141

Toyal Europe S.A.S.U.

14 rue Gambetta 78600 Le-Mesnil-Le-Roi, France
TEL: +33-1-34-931020